



**REQUEST FOR PROPOSAL**

**FOR**

**ARMORED TRANSPORT, SECURE MOBILE  
VAULT & CURRENCY PROCESSING SERVICES**

**City of Vallejo  
Solano County, California 94590**

**SOLICITATION NO. 2017-RFP-04**

**PROPOSALS DUE  
NOVEMBER 28, 2017**

**ISSUED FOR SOLICITATION**

**NOVEMBER 02, 2017**

## **I. NOTICE TO CONTRACTORS**

**NOTICE IS HEREBY GIVEN** that sealed proposals are requested by the Solano County Transit, a joint powers authority (“SolTrans”) serving the residents of the Cities of Vallejo and Benicia, California, for “Armored Transport, Secure Mobile Vault & Currency Processing Services”. All proposals shall be submitted in response to the conditions of this “REQUEST FOR PROPOSALS for Armored Transport, Secure Mobile Vault & Currency Processing Services (hereinafter referred to as RFP),” dated November 02, 2017, said RFP being on file in the offices of SolTrans located at 311 Sacramento Street, Vallejo, California, 94590.

Proposals must be contained in a sealed envelope and appropriately labeled as described in the Section entitled Schedule & Submittal Instructions. Proposals must be received at the offices of SolTrans, at or before 4:00 p.m. PST on Tuesday November 28, 2017.

Proposals received after 4:00 pm PST on November 28, 2017 will be considered late and may be excluded from consideration.

Additional Submission instructions are included in Section 3 of the RFP.

### **A. Obtaining Documents**

Proposal documents may be obtained in person at the SolTrans office at 311 Sacramento Street, Vallejo, California, 94590 or electronically at:

<http://www.soltransride.com/about-soltrans/doing-business-with-soltrans/procurements>

Documents requested by mail will be packaged and sent postage paid.

### **B. Validity of Proposals**

Proposals and subsequent offers shall be valid for a period of not less than ninety (90) days after proposal deadline.

### **C. Pre-Proposal Site Visit**

A non-mandatory pre-proposal site visit may be held for this project at 2:00 p.m. PST on Monday November 13, 2017 at the SolTrans Operations and Maintenance (O&M) Facility, located at 1850 Broadway Street, Vallejo, CA 94589. PROPOSERS interested in attending the pre-proposal site visit must contact SolTrans no later than 11:00 a.m. the day of the site visit to confirm attendance. PROPOSERS should contact Larry Deleon Guerrero at (707) 736-6990 or via email at [larry@soltransride.com](mailto:larry@soltransride.com) to confirm attendance.

Proposers are reminded that any changes to the RFP will be made by written addenda only and nothing stated at the pre-proposal site visit shall change or qualify in any way any of the provisions in the RFP and shall not be binding on SolTrans.

### **D. Proposal Inquiries and Contacts**

Inquiries may be submitted via email, personal delivery, by mail (return receipt requested), or by facsimile (FAX). Proposal inquiries submitted by personal delivery shall be deemed received at the date and time of delivery. SOLTRANS is under no obligation to consider any proposal inquiries that are not submitted as provided herein.

For more information and all communications regarding this Request for Proposal, including those seeking clarification of the RFP documents, must be submitted in writing (email preferred), and should be directed to:

Kristina Botsford  
Finance & Administration Manager  
kristina@soltransride.com  
Ph/Fax: 707-786-6987  
311 Sacramento Street  
Vallejo, CA 94590

All emails sent to kristina@soltransride.com will receive a brief confirmation email in return. Proposal inquiries submitted by facsimile (Fax) will receive a brief confirmation in return. PROPOSERS who do not receive a confirmation within one day of submitting questions or requests for clarification should contact Kristina Botsford to confirm receipt or to resubmit questions and clarifications.

#### **E. Equal Employment Opportunity and DBE/SBE Requirements**

It is SolTrans' policy to ensure that Contractors shall not discriminate based on race, color, religious creed, national origin, ancestry, sex, physical disability or other protected class in the performance of SolTrans contracts.

Although there is no specific goal or requirement to use participation by Disadvantage Business Enterprises (DBE) for this project, SolTrans highly encourages the participation of Disadvantaged Business Enterprises (DBE). SolTrans encourages all prime Contractors to utilize qualified SBE (Small Business Enterprise) sub-Contractors on SolTrans projects, and promotes the direct purchase of goods from qualified SBEs by utilizing SBE vendors when such vendors are available and the price of the goods or services sought is reasonable.

# Table of Contents

SECTION 1. GENERAL INFORMATION .....	1
1.1 Introduction.....	1
1.2 Organization of the RFP .....	1
1.3 SolTrans’ Rights .....	2
1.4 PROPOSERS’ Responsibilities .....	2
1.5 Consequence of Submission of Proposal.....	3
1.6 Cost of Submitting Proposals.....	4
SECTION 2. BACKGROUND.....	5
2.1 Agency Description .....	5
2.2 Project Description.....	5
SECTION 3. SCHEDULE & SUBMITTAL INSTRUCTIONS .....	7
3.1 Schedule.....	7
3.2 Proposal Submission.....	7
3.3 Proposal Content.....	8
3.4 Pre-Proposal Site Visit.....	9
3.5 Written Questions .....	9
3.6 Addenda .....	10
3.7 Clarifications/Interviews.....	10
3.8 Accuracy in Reporting Requested Information .....	10
SECTION 4. PROPOSAL REQUIREMENTS.....	11
4.1 Performance Requirement .....	11
4.2 Content of Technical Proposals .....	11
4.3 Content of Price Proposal .....	13
4.4 Insurance .....	14
4.5 Willingness to Accept Proposed Arrangements .....	14
SECTION 5. EVALUATION AND SELECTION.....	15
5.1 Evaluation and Selection Process .....	15
5.2 Evaluation Criteria.....	15
5.3 Notification to Unsuccessful PROPOSERS .....	16
SECTION 6. PROTEST PROCEDURES .....	17

6.1	Definitions.....	17
6.2	Protest Procedures.....	17
6.2.1	Filing Procedure:.....	17
6.2.2	Confidentiality: .....	18
6.2.3	Withholding of Award: .....	18
6.2.4	Processing the Request: .....	18
6.2.5	Notification: .....	18
6.2.6	Appeal: .....	18
SECTION 7. SCOPE OF SERVICES .....		20
7.1	GENERAL REQUIREMENTS .....	20
7.2	WORK SITE LOCATION .....	20
7.3	CASH COLLECTION AND ARMORED TRANSPORTATION SERVICES .....	21
7.4	MOBILE VAULT PICK UP AND CURRENCY PROCESSING SERVICES.....	21
7.5	ANNUAL SCHEDULE.....	22
7.6	LICENSE AND PERMITS.....	22
7.7	PERSONNEL .....	23
7.8	EQUIPMENT .....	23
7.9	MATERIALS AND LABOR .....	23
7.10	OTHER REQUIREMENTS .....	23
7.10.1	CASH CONTROL.....	23
7.10.2	KEY CONTROL .....	24
7.10.3	DAMAGE.....	24
APPENDIX A: REQUIRED FORMS .....		25
APPENDIX B: SOLTRANS STANDARD CONTRACT .....		31
APPENDIX C: MOBILE VAULT DIMENSIONS .....		32

## **SECTION 1. GENERAL INFORMATION**

### **1.1 Introduction**

SolTrans is issuing this Request for Proposals (RFP) to select a Contractor using Best Value Procurement Guidelines to Securely transfer cash and coin deposits, mobile vault transport, and cash counting services as described in the scope of services.

SolTrans has prepared a Scope of Services (see Section 7) and a Draft Standard Contract (see Appendix B) that define the scope of services, performance standards, term, compensation mechanism, insurance requirements, and other contractual issues.

The contract terms shall be for three (3) years from the contract start date, with two (2) one-year terms at the option of SolTrans.

Proposers shall provide a clear, concise explanation of the proposer's capability to satisfy the requirements of this RFP and the Attached Standard Contract. Each proposal shall be submitted in the requested format and shall provide all pertinent information, including but not limited to information relating to the contractor's capability, experience, financial resources, management structure and key personnel, and other information as specified in Section Four (4) or otherwise required in this RFP.

Solano County Transit is referred to as "SolTrans". Proposers are referred to as the "PROPOSER" or "Bidder" or "Contractor" or "CONTRACTOR".

### **1.2 Organization of the RFP**

The RFP is organized into seven (7) sections, and includes Appendices A, B, and C.

Section 1 consists of information regarding the introduction and purpose, RFP organization, SolTrans rights, PROPOSER responsibilities, contact restrictions, consequence of proposal submission, and cost of submitting proposals.

Section 2 contains background information, including relevant project and other related information.

Section 3 identifies the procurement schedule and proposal submittal instructions.

Section 4 provides instructions on the required content of the proposals.

Section 5 describes the evaluation and selection process and criteria.

Section 6 identifies the protest procedures.

Section 7 describes the type of services SolTrans is requesting to be performed.

The appendices contain additional information required for proposal preparation including the Required Forms, the Draft Standard Contract, and Mobile Vault Dimensions.

### 1.3 SolTrans' Rights

The SolTrans' rights include, but are not limited to, the following:

- ❑ Issuing addenda to the RFP, including extending or revising the time line for submittals.
- ❑ Withdrawing, reissuing, or modifying the RFP.
- ❑ Requesting clarification and/or additional information from any PROPOSER at any point in the procurement process.
- ❑ Executing a Contract with a PROPOSER on the basis of the original written proposal (without conducting interviews) and/or any other information submitted by the PROPOSER during the procurement process.
- ❑ Rejecting any or all proposals, waiving irregularities in any proposals, accepting or rejecting all or any part of any proposals, waiving any requirements of the RFP, as may be deemed to be in the best interest of SolTrans.
- ❑ Proposals shall be evaluated on a "Best Value" basis. This solicitation will utilize the Federal Transit Administration's (FTA) Best Practices Manual's definition for "Best Value" as follows:

*"Best Value" is a selection process in which proposals contain both price and qualitative components, and award is based upon a combination of price and qualitative considerations. Qualitative considerations may include technical design, technical approach, quality of proposed personnel, and/or management plan. The award selection is based upon consideration of a combination of technical and price factors to determine (or derive) the offer deemed most advantageous and of the greatest value to the procuring agency.*

- ❑ SolTrans may, but is not bound to, commence negotiations with selected PROPOSERS deemed by SolTrans to be within the "competitive range". The "competitive range" will consist of those proposals which have a reasonable chance, following committee evaluation of proposals in accordance with the published RFP evaluation criteria, of being selected for award. The competitive range may be selected and refined by the selection committee at any time following initial review of the written proposals.
- ❑ SolTrans reserves the right to audio and video record any and all live meetings, including conferences and interviews, with potential and actual PROPOSERS and staff during any and all phases of this RFP process. All recordings shall be deemed confidential until after the notice of intent to award is issued with the exception of open public meetings.

### 1.4 PROPOSERS' Responsibilities

It is the responsibility of each PROPOSER to:

- ❑ Examine this RFP, including all appendices and the attached Draft Standard Contract, thoroughly.
- ❑ Register as a SolTrans Vendor at [www.soltransride.com](http://www.soltransride.com).
- ❑ Become familiar with local conditions that may affect cost, permitting, progress, performance, or services described in this RFP.

- Consider all federal, state and local laws, statutes, ordinances, regulations and other applicable laws, rules and regulations that may affect costs, permitting, progress, performance, or services.
- Clarify, with SolTrans, any conflicts, errors, or discrepancies in this RFP prior to the Proposer Questions/Clarifications submission deadline as provided in the RFP Schedule.
- Agree not to collaborate or discuss with other PROPOSERS the content of the proposal or service fees proposed.
- Prior to submitting a proposal, each PROPOSER will, at his/her own expense, make or obtain any additional examinations, investigations, and studies; and obtain any additional information and data that may affect costs, permitting, progress, performance or furnishing of the project that PROPOSER deems necessary to determine its proposal.
- Each PROPOSER shall use mail, fax, email or other delivery method or mechanism at its own risk, and SolTrans shall not be obligated to accept or respond to any submission that is delayed due to delivery failures.

### **1.5 Consequence of Submission of Proposal**

The submission of a proposal will constitute a binding representation and warranty by the PROPOSER that the PROPOSER has reviewed all aspects of the RFP and its proposal; that the PROPOSER is aware of the applicable facts pertaining to the RFP process, its procedures and requirements; that the PROPOSER has read and understands the RFP and has complied with every requirement; that without exception the proposal is premised upon performing and furnishing the services and equipment required by this RFP and the attached Contract and such means, methods, techniques, sequences or procedures as may be indicated in or required by this RFP and the Contract; and that the RFP is sufficient in scope and detail to indicate and convey understanding of all terms and conditions for performance and furnishing of the project.

The submission of a proposal shall not be deemed an agreement between the PROPOSER and SolTrans. The proposal is a contractual offer by the PROPOSER to perform services in accord with the proposal. Specifically, the following provisions apply:

- SolTrans shall not be obligated to respond to any proposal submitted nor be bound in any manner by the submission of a proposal.
- Acceptance of a proposal by SolTrans obligates the PROPOSER to enter into a Contract with SolTrans for the performance of the services chosen by SolTrans at its sole discretion.
- The Contract shall not be binding or valid against SolTrans unless and until it is executed by SolTrans and the selected PROPOSER, and any required bonding, insurance, or other surety guarantee has been accepted by SolTrans.

The proposals received shall become the exclusive property of SolTrans. At such time as a Notice of Intent to Award is issued, all proposals submitted in response to this RFP shall become a matter of public record and shall be regarded as public records, with the exception of those elements in each proposal which are trade secrets as that term is defined in Government Code section 6254.7 and which are so marked as “TRADE SECRET,” “CONFIDENTIAL” or “PROPRIETARY”. Every page of the proposal containing such information shall be clearly



marked as such on the top of each page containing information corresponding to the designation. However, proposals that indiscriminately identify all or most of the proposal as exempt from disclosure with justification may be found technically unacceptable. SolTrans shall not in any way be liable or responsible to any PROPOSER or other person for any disclosure of any such records or portions thereof, whether the disclosure is deemed to be required by law, by an order of a court, or occurs through inadvertence, mistake, or negligence on the part of SolTrans or its officers, agents or employees.

## **1.6 Cost of Submitting Proposals**

The cost of investigating, preparing, and submitting a proposal is the sole responsibility of the PROPOSER and shall not be chargeable in any manner to SolTrans. SolTrans will not reimburse any PROPOSER for any costs associated with the preparation and submission of a proposal, including but not limited to, expenses incurred in making an oral presentation, participating in an interview, or negotiating a Contract with SolTrans.

## **SECTION 2. BACKGROUND**

This section includes background information relevant to the scope of services. Please note that the data provided is for informational purposes only. SolTrans does not certify the accuracy of the information provided. PROPOSER should not rely on this section for developing proposals and service costs.

### **2.1 Agency Description**

Solano County Transit (SolTrans) is a Joint Powers Authority that provides public transportation to the southern Solano County cities of Vallejo and Benicia.

The SolTrans joint powers agreement was approved in the Fall of 2010 by the City of Benicia, the City of Vallejo, and the Solano Transportation Authority to build a unified public transit system in southern Solano County. On July 1, 2011, SolTrans officially assumed responsibility for transit operations and all its related public transit programs, previously provided for by its member cities of Vallejo and Benicia.

SolTrans provides local and express bus service to the Solano County cities of Vallejo, Benicia and Fairfield, with express bus service connecting to the Contra Costa County communities of El Cerrito, Pleasant Hill and Walnut Creek, regional connections to BART. There are currently 16 routes in operation. The SolTrans fixed route fleet consists of 21 diesel hybrids, 3 conventional diesels, and two new battery electric buses for local service and 21 over the road buses for express service, of which 6 are powered by compressed natural gas and the remainder are diesel powered.

In addition to fixed route service, SolTrans provides ADA complementary paratransit bus service, general public dial-a-ride service within Benicia, and administers Local and Intercity Taxi Scrip Programs. Solano County's Intercity Taxi Scrip Program is an innovative, award winning program that provides direct service between cities in Solano County for ambulatory ADA Paratransit qualified individuals. The demand response fleet consists of 12 gasoline powered cutaway vehicles.

### **Organizational Structure**

There are 15 staff that work directly for SolTrans located at 311 Sacramento Street, Vallejo Transit Center ("VTC"). The Agency contracts with National Express Transit ("Next") to perform the operations and maintenance functions of the transit system. There are approximately 100 Next employees who consist of drivers, road supervisors, dispatchers, customer service representatives, mechanics for vehicle, bus stop maintenance, and maintenance of the operation and maintenance facility at 1850 Broadway Street, Vallejo. In addition, there are five Next management personnel. Customer service functions are performed at VTC as well as at the operations and maintenance facility.

### **2.2 Project Description**

Solano County Transit is seeking to award a contract for Armored Transport, Secure Mobile Vault & Currency Processing Services to a highly qualified firm capable of providing turnkey

services to meet SolTrans' cash handling and reporting needs. The services required would include secure armored vehicle service to pick up cash bags and prepared deposits, as well as to pick up SolTrans' mobile vault bins, and under security and video surveillance open and verify currency and coin proceeds. The service provider will prepare the cash proceeds for deposit into SolTrans' designated bank as well as report to SolTrans all currency and coin extracted and deposited.

SolTrans desires to establish a three-year base contract with the successful Contractor, with an option to renew for up to two (2) additional one-year terms, subject to agreeable pricing modifications and service performance.

The scope of services in Section 7 below will describe the required services in more detail.

## SECTION 3. SCHEDULE & SUBMITTAL INSTRUCTIONS

### 3.1 Schedule

SolTrans will attempt to adhere to the following schedule. This schedule may change due to unforeseen circumstances and at the sole discretion of SolTrans. Changes will be conveyed to proposers at the earliest opportunity possible through written addenda.

Activity	Date
Request For Proposal Release Date	NOVEMBER 02, 2017
Non-Mandatory Pre-Proposal Site Visit: Beginning at 2:00 PM at 1850 Broadway Street, Vallejo, CA and ending at 311 Sacramento Street, Vallejo, CA. PROPOSERS must confirm attendance.	NOVEMBER 13, 2017
Deadline for written RFP Clarifications/Questions	NOVEMBER 16, 2017, 4:00 P.M. PST
Proposals Due	NOVEMBER 28, 2017, 4:00 P.M. PST
Proposal Review, Negotiations, Scoring	NOVEMBER 28-30, 2017
Notice of Intent to Award	DECEMBER 04, 2017
Projected Award Date (Board Meeting)	DECEMBER 21, 2017
Projected Contract Start Date	JANUARY 2, 2018

*All Dates Following Proposal Submission Date are Estimated*

### 3.2 Proposal Submission

Sealed proposals must be received by Solano County Transit, in accordance with the Notice to Contractors and the RFP Schedule listed in Section 3.1. If not previously delivered, proposals may be hand delivered to SolTrans' Ticket Office at the address below, on the due date at the time and on the date listed in the Notice to Contractors and the RFP Schedule listed in Section 3.1. Proposals shall be in sealed packets labeled "2017-RFP-04 – Armored Transport, Secure Mobile Vault & Currency Processing Services" - [Insert Firm Name Here] to:

Kristina Botsford  
Finance & Administration Manager  
311 Sacramento Street  
Vallejo, CA 94590

Proposals should be limited to 20 pages unless otherwise specified in the Solicitation. This 20 page limitation does not include SolTrans Forms and Certifications, resumes and cost proposal. Standard marketing materials and brochures are included in the page limitation and are discouraged.

#### □ **Technical Proposal**

One (1) original bound, three (3) standard three hole punched copies of proposal and one (1) electronic PDF copy on a USB flash drive must be received by SolTrans by the RFP Proposal due date and time listed in the Notice to Contractors and the RFP Schedule listed in Section 3.1. Technical proposals must be sealed and marked "Technical Proposal for 2017-RFP-04 – Armored Transport, Secure Mobile Vault & Currency Processing Services". Proposals received after the specified date and time provided in the Notice to Contractors shall be considered late and may be excluded from consideration.

#### □ **Price Proposal**

One (1) original bound, three (3) standard three hole punched copies of proposal and one (1) electronic PDF copy on a USB flash drive must be received by SolTrans by the RFP Proposal due date and time listed in the Notice to Contractors and the RFP Schedule listed in Section 3.1. Cost Proposals must be in a separate sealed envelope and labeled "Cost Proposal for 2017-RFP-04 – Armored Transport, Secure Mobile Vault & Currency Processing Services". Proposals received after the specified date and time provided in the Notice to Contractors shall be considered late and may be excluded from consideration.

### **3.3 Proposal Content**

All proposals must include the following:

- **Cover letter** that provides the following information:
  - a. Name, address, and telephone email and fax number of PROPOSER and key contact person.
  - b. Description of type of business organization (e.g., corporation, partnership, limited liability company, including joint venture teams and subcontractors) submitting proposal.
  - c. Name of entity that would sign a Contract if one is negotiated for this project.
  - d. A written statement warranting that the requirements of the project as described in this RFP, its appendices and all addenda, by listing all addenda and dates received hereto, have been reviewed and the PROPOSER has conducted all necessary due diligence to confirm material facts upon which the proposal is based.
  - e. A written statement acknowledging validity of the proposal contents, costs, and services fees for a period of 90 days after the submission deadline.
  - f. An officer or agent of the PROPOSER who is duly authorized to bind the company to the proposal must sign the cover letter.

- ❑ **Executive Summary** (not to exceed 2 pages) that highlights the major elements of PROPOSER'S qualifications and proposal. All information should be provided in a concise manner.
- ❑ **Responses to all required elements requested in Section 4.** The proposal responses shall be organized in identifiable sections as outlined in Section 4 of this RFP, so that all requested information can be readily found.
- ❑ **Completion and inclusion of all required forms (as listed in Appendix A).** All PROPOSERS shall complete, sign and include all required forms in their proposal. Any proposal that does not contain the required forms may be deemed non-responsive.
- ❑ **All pages** of the proposal must be numbered for reference.

SolTrans may waive any immaterial technical variations in its sole discretion.

### **3.4 Pre-Proposal Site Visit**

A pre-proposal site visit (if appearing in the RFP) will be held at the time and place indicated in the Notice to Contractors. Questions received in writing, as well as any other questions brought up at the conference, will be answered, to the extent possible, at that time.

Oral questions which are material to the solicitation will be recorded at the conference, and questions and answers will be posted to SolTrans website: [www.soltransride.com](http://www.soltransride.com).

Any changes, interpretations, or clarifications considered necessary by SolTrans in response to PROPOSER questions will be posted online at the above website addresses as addenda. Only answers issued in writing and/or posted on the SolTrans website by SolTrans will be binding on SolTrans. Oral and other interpretations or clarifications including those provided at the pre-proposal conference will be without legal effect.

### **3.5 Written Questions**

PROPOSERS may submit written questions and requests for clarification or additional information regarding the meaning or intent of the RFP content, its process and appendices to be received no later than 4:00 p.m. PST on the date listed in the RFP Schedule.

The preference for method of submission of written questions is via email to the following person:

Kristina Botsford  
Finance & Administration Manager  
Email address: [kristina@soltransride.com](mailto:kristina@soltransride.com)  
Telephone/FAX: (707) 736-6987

SolTrans will not respond to questions received after the time and date listed in the RFP Schedule. Due consideration will be given to the time it may take to respond to SolTrans' final responses to questions. All written questions and answers between SolTrans and the PROPOSERS will be documented and posted at the website addresses listed in Section 3.4.

### **3.6 Addenda**

Modifications to this RFP shall be made only by written addenda, issued by SolTrans, to all RFP holders of record. In order to receive Addenda and submit questions regarding the RFP, all PROPOSERS must register with SolTrans at [www.soltransride.com/about/doing-business-with-soltrans/vendor-registration-form/](http://www.soltransride.com/about/doing-business-with-soltrans/vendor-registration-form/).

Verbal instructions, interpretations, and changes shall not serve as official expressions and shall not be binding on SolTrans. All cost adjustments or other changes resulting from said addenda shall be taken into consideration by PROPOSERS and included in their proposals.

### **3.7 Clarifications/Interviews**

SolTrans reserves the right to base its decision solely on the written proposals without performing interviews. PROPOSER may be asked to clarify proposal information through writing or verbally via conference call. The clarification period will begin when the proposals are submitted.

Solano County Transit reserves the right to audio and/or video record any and all live meetings, including conferences and interviews, with potential and actual PROPOSERS and staff during any and all phases of this RFP process.

### **3.8 Accuracy in Reporting Requested Information**

Information submitted as part of the proposal will be subject to verification. Inaccurate information or information that is misleading will, at the sole discretion of SolTrans, be grounds for removal of a proposal from further consideration. Should a PROPOSER be awarded an Contract as a result of this RFP, inaccurate or misleading information included in the proposal and subsequently discovered by SolTrans will be, at the SolTrans' sole discretion, grounds for default.

## **SECTION 4. PROPOSAL REQUIREMENTS**

### **4.1 Performance Requirement**

The successful PROPOSER (hereafter “CONTRACTOR”) will be required, at all times during the terms of the Contract, to perform all services diligently, carefully, and in a professional manner; and to furnish all labor, supervision, as required under the Contract. Any proposal submitted must be for the entire scope of services. The CONTRACTOR shall conduct all work in the CONTRACTOR’s own name and as an independent contractor, and not in the name of, or as an agent for SolTrans.

### **4.2 Content of Technical Proposals**

Technical proposal shall be in a separate sealed envelope and clearly marked “Technical Proposal for 2017-RFP-04 – Armored Transport, Secure Mobile Vault & Currency Processing Services”.

The following items must be included in the PROPOSER’S technical proposal for it to be considered complete and responsive.

#### **□ Documentation of Qualifications and Related Experience**

This section of the proposal should demonstrate the ability of the Contractor to satisfactorily perform the required work by way of its demonstrated competence and experience in the services to be provided; the nature and relevance of similar work currently being performed or recently completed; competitive advantages over other firms in the same industry; strength and financial stability, and supportive client references.

PROPOSER shall demonstrate at least five (5) years of successful experience in providing Armored Transport, Secure Mobile Vault and Currency Processing Services. PROPOSER shall provide evidence that it meets the licensing and insurance requirements.

Provide a brief narrative description of your firm’s background and experience in providing Armored Transport, Secure Mobile Vault & Currency Processing Services as described in the scope of services section of this RFP and as required by the contract. Explain why your firm is best qualified to provide the services.

PROPOSER shall include a concise but complete narrative describing the background and experience of each member of your proposed team. Include two organizational charts. The first chart illustrating the firm’s staffing structure, including duties/titles and the second chart illustrating the names, reporting structure, brief job description, and number of years with PROPOSER’S organization for each member of the proposed project team. If the scope of work is limited to work that does not require a team, then the charts are not required.

The descriptions should demonstrate your firm’s and your team’s experience relevant to the scope, costs, conditions and delivery method of the work or projects listed in this RFP.



## □ **Client References**

Provide a client reference list of no fewer than five (5) government clients for which the PROPOSER provides or has provided similar work or services as those requested by SolTrans. Client references shall be current (where PROPOSER is currently providing services to the client) or recent (where within the past three calendar years PROPOSER has provided services to the client). The Client reference contact information shall include name of agency, contact person, telephone numbers, and a valid email. Indicate which of the government clients are in the transit industry.

## □ **Technical Approach and Methodology**

Describe your firm's approach, capacity, and management philosophy towards providing the scope of services described in the RFP. As part of the approach to the work, a cash collection system plan will need to be included in the Technical portion of the proposal. It should address, at a minimum:

1. The dual custody security of cash fare collections, and revenue on-hand;
2. The secure dual custody process for transporting SolTrans' mobile vault bin to PROPOSER's secure processing center;
3. The PROPOSER's proposed system for counting the cash fares: counting coins, counting bills – must include the proposed process for opening and extracting cash from the mobile vault at PROPOSER's secure processing center;
4. The PROPOSER'S process for depositing cash fares in a designated SolTrans bank account;
5. The PROPOSER'S process for emailing daily, monthly, and annual revenue reconciliation reports, including providing sample reports;
6. Information on those individuals who would be assigned to work with SolTrans including a description of their experience in providing these services.
7. Describe the PROPOSER's plan for providing customer service to SolTrans.

This section should establish the Contractor's understanding of SolTrans' objectives, ability to meet the objectives, and provide a concise plan for how this will be accomplished.

## □ **Financial Capabilities**

PROPOSER shall provide a summary of its firm's financial stability and capacity.

## □ **Proposed Quality Control Program**

Include a description of the quality control program.

## □ **Implementation Plan**

The PROPOSER shall include a detailed Implementation Plan. This plan shall address, at a minimum, the activities and procedures that will be followed to ensure the smooth start-up of the project, and if necessary, transition from the current provider. The plan should also document recruitment and training schedules, start-up plan, and acquisition of necessary personnel,

equipment, permits, licenses and any other activities necessary to begin work on the scope of services.

❑ **Exceptions to the Draft Standard Contract Provisions**

PROPOSER shall review and provide in its response any exceptions to the draft standard contract in detail.

❑ **Certifications, Forms and Declarations (Appendix A)**

PROPOSER shall sign and complete the following forms:

1. Price / Cost Proposal
2. Non-Collusion Affidavit for Contractor
3. Certification Regarding Debarment, Suspension, and other Responsibility Matters
4. Listing of Subcontractors
5. Contractor Questionnaire

**4.3 Content of Price Proposal**

Price proposal shall be in a separate sealed envelope and clearly marked “Price proposal for 2017-RFP-04 – Armored Transport, Secure Mobile Vault & Currency Processing Services”.

The following items must be included in the PROPOSER’s Price proposal for it to be considered complete and responsive.

❑ **Price Proposal (Form 1, Appendix A)**

PROPOSER shall provide Price proposals (using Appendix A, Form 1, Price Proposal) which shall equal the total proposed cost to complete the scope of work.

The Price Proposal must include a fixed price for the standard pick up and drop off duty at each location, a unit cost (per bag, strap, per vault) for cash counting services as described in the scope of services and the proposed methodology/approach provided by the Proposer.

Unless otherwise indicated, the proposed fixed prices will remain the same for the three year base term of the contract. If the PROPOSER anticipates an increase in the optional years, please provide a fixed price proposal for option years. Costs for option years will be evaluated.

The proposal must include any surcharges (i.e. fuel surcharge) which may be intended by the Proposer.

#### **4.4 Insurance**

- Insurance must be provided for in accordance with the Draft Standard Contract in Appendix B.

#### **4.5 Willingness to Accept Proposed Arrangements**

Submission of a proposal constitutes an offer to enter into a binding legal contract with SolTrans on all of the terms specified in this RFP, including Appendix A - Required Forms, and Appendix B - Draft Standard Contract.

## SECTION 5. EVALUATION AND SELECTION

### 5.1 Evaluation and Selection Process

Proposals submitted in response to this RFP will be evaluated by the Evaluation Committee established by SolTrans, in accordance with the criteria and procedures set forth in this Request for Proposals. This section incorporates those rights and procedures noted in RFP Section 1.3 - SolTrans' Rights.

The primary desire of Solano County Transit for this procurement is to ensure an award will be made based on the highest quality of service that best matches Solano County Transit's requirements using the Best Value methodology.

The Evaluation Committee will submit its recommendation to the SolTrans Board of Directors for an award to be made based upon the Evaluation Committees' determination of the responsible Proposer whose proposal is most advantageous to SolTrans.

### 5.2 Evaluation Criteria

The following items constitute the evaluation criteria (and their respective weights), which SolTrans will use in evaluating proposals submitted in response to this RFP.

<b>Evaluation Criteria</b>	<b>Points</b>
<b>Technical Proposal:</b>	
PROPOSER's qualifications and experience	50
Project understanding/approach. Ability to meet the technical requirements of the specifications	40
References	20
<b>Cost Proposal</b>	40
Total Possible Points	150

PROPOSERS who remain in the competitive range following the initial evaluation of written proposals may be invited (only if interviews are required) to demonstrate their qualifications, experience and project approach before the Evaluation Committee. There will not be a separate "interview" score. The Evaluation Committee may raise or lower criteria scores based on information and clarifications gained during the interview process. Reasons for such changes will be documented.

SolTrans reserves the right to make an award solely on a PROPOSER'S written proposal alone, and is not required to conduct interviews.

### **5.3 Notification to Unsuccessful PROPOSERS**

All PROPOSERS shall be notified of SolTrans Evaluation Committee's recommendations by way of a Notice of Intent to Award (this will serve as the final committee recommendation) within five (5) working days of said recommendation.

## **SECTION 6. PROTEST PROCEDURES**

### **6.1 Definitions**

The following terms as may be used in this section are defined below:

- a. "Proposal" refers to an offer or proposal as used in the context of this Request for Proposals.
- b. "Day" refers to working day of SolTrans, where SolTrans Administrative Office, located at 311 Sacramento Street is open to the public.
- c. "Date of Notification of Intent to Award" refers to the calendar date that SolTrans communicates to PROPOSERS which proposing firms, corporation, partnership or individual are recommended for award.
- d. "File" or "Submit" refers to date and time of receipt by SolTrans of protest materials.
- e. "Interested Party" means an actual or prospective PROPOSER whose direct economic interest would be affected by the award of Contract or by failure to award Contract.
- f. "Protester" refers to interested party filing a protest or appeal.
- g. "FTA" means Federal Transit Administration.

### **6.2 Protest Procedures**

#### **6.2.1 Filing Procedure:**

Protests dealing with restrictive specifications or alleged improprieties in solicitation must be filed no later than ten (10) working days prior to bid opening or closing date for receipt of proposals. Any other protest must be filed no later than three (3) working days after:

- 1. Notification of Intent to Award is issued for award of contract if the contract is awarded by SolTrans Board per staff recommendation; or
- 2. Notification of Award is issued if the SolTrans Board has delegated award authority to the Purchasing Agent or SolTrans Board does not award the contract according to the Notification of Intent to Award.

Protests shall be in writing and addressed to the Executive Director.

The protest shall identify the protestor, contain a statement officially declaring a protest and describing the reasons for the protest, and provide any supporting documentation. Additional materials in support of the initial protest will only be considered if filed within the time limit specified above. The protest shall indicate the ruling or relief desired from SolTrans.

### **6.2.2 Confidentiality:**

Materials submitted by a protester will not be withheld from any interested party, except to the extent that the withholding of information is permitted or required by law or regulation. If the protest contains proprietary material, a statement advising of this fact may be affixed to the front page of the protest document and the alleged proprietary information must be so identified wherever it appears.

### **6.2.3 Withholding of Award:**

When a protest is filed before opening of bids or closing date of proposals, the bids will not be opened prior to resolution of the protest, and when the protest is filed before award, the award will not be made prior to resolution of the protest, unless the Awarding Authority determines that:

- a) Items to be procured are urgently needed, or delivery or performance will be unduly delayed by failure to make award promptly; or
- b) Failure to make award will cause undue harm to SolTrans.

In the event an award is to be made while a protest is pending, the Federal Transit Administration shall be notified if Federal funding is involved.

### **6.2.4 Processing the Request:**

- a) The Executive Director shall respond to the protestor within five (5) working days of receiving the protest. A conference on the merits of the protest may be held with the protester.
- b) Any additional information required by SolTrans from the protester shall be submitted as expeditiously as possible, but no later than three (3) days after receipt of such request.

### **6.2.5 Notification:**

The Executive Director shall notify the protester of a decision regarding the protest no later than ten (10) days following receipt of all relevant information.

### **6.2.6 Appeal:**

If a protester is not satisfied with the decision made by the Executive Director the protester may appeal the decision to the Awarding Authority by way of a letter to the Executive Director no later than three (3) working days after notification of denial of the protest by the Executive Director. If Federal funds are involved, the protester may file protest with the Federal Transit Administration appealing the final decision of the Awarding Authority. Review by FTA will be limited to:

- a) Violation of Federal law or regulations.
- b) Violation of SolTrans' protests procedures described herein, or failure by SolTrans to review protest.

Protests must be filed with FTA (with a concurrent copy to SolTrans) within five (5) days after the Awarding Authority renders a final decision, or five (5) days after the protester knows, or has

reason to know, that the Awarding Authority failed to render a final decision. After five (5) days, SolTrans will confirm with FTA that FTA has not received protest on the contract in question.

Circular 4220.1F, the FTA's Third Party Contracting Guidance, is available for review at SolTrans office. A copy may be obtained from FTA at the following address:

Federal Transit Administration  
Region IX  
201 Mission Street – Suite 2210  
San Francisco, California 94105

SolTrans shall not be responsible for any protests not filed in a timely manner with FTA.

In the event an award is to be made while a protest is pending, the Federal Transit Administration shall be notified if Federal funding is involved.



## **SECTION 7. SCOPE OF SERVICES**

NOTE: For the purposes of Section 7 “Scope of Services,” the term “Contractor” or “Consultant” represents the successful PROPOSER(S)

### **7.1 GENERAL REQUIREMENTS**

- A. Timely pick up of customer-owned and sealed GFI mobile vault unit at 1850 Broadway Street, Vallejo, CA 94589 on 2 designated days per week, currently Tuesdays and Fridays. Forklift provided by SolTrans on premises.
- B. Timely pick-up of cash bags and prepared deposits at two worksite locations: 311 Sacramento Street, Vallejo, CA 94590 and 1850 Broadway Street, Vallejo, CA 94589 on 2 designated days per week. Transport cash bags via armored transport to SolTrans’ worksite locations. Safeguard and deliver all prepared deposits to SolTrans’ designated bank.
- C. All SolTrans locations are secure sites and require advance notification of at least fifteen (15) minutes via telephone call to a specified telephone number prior to contractor arrival for pick up and drop off. Contractor is advised that showing up unannounced may result in delayed assistance from SolTrans staff and wait times may take up to fifteen (15) minutes before SolTrans staff may be available to assist Contractor.
- D. Safeguard and deliver sealed GFI mobile vault unit via armored transport to contractor’s designated secure location two (2) days each week for currency and coin counting and verification. Contractor is required to provide forklift at their secure cash counting location.
- E. Open sealed mobile vault bin for counting (Keys provided by SolTrans), under dual custody and video camera surveillance at Contractor’s secure site the same day or following business day from the date of pick up. Immediately after opening mobile vault bin, count and verify all currency and coin removed from the mobile vault bin.
- F. Prepare verified currency and coin proceeds for deposit. Safeguard and deposit proceeds to SolTrans’ designated bank via armored transport.
- G. Provide detailed report of all currency and coin extracted and counted from the mobile vault bin via email or fax to the specified SolTrans staff within two (2) business days of pick up.
- H. Return empty GFI mobile vault bin to 1850 Broadway Street, Vallejo, CA 94589 on two (2) designated days each week.

### **7.2 WORK SITE LOCATION**

- A. Pick up Locations:
  - a. 1850 Broadway Street, Vallejo, CA 94589
  - b. 311 Sacramento Street, Vallejo, CA 94590
- B. Cash Bag Delivery Locations:
  - a. 1850 Broadway Street, Vallejo, CA 94589
  - b. 311 Sacramento Street, Vallejo, CA 94590

- C. Mobile Vault Delivery/Cash Counting Location:
- a. Contractor's secure coin and currency processing center (TBD)

### **7.3 CASH COLLECTION AND ARMORED TRANSPORTATION SERVICES**

- A. Location 1: Bus Operations and Maintenance Facility at 1850 Broadway Street, Vallejo, CA
- a. Pick up and drop off between 8:00 a.m. – 4:00 p.m.
  - b. Transfer of money must be done at the back of the bus yard and not at the front of the building. Driver must call prior to arrival to gain access through the security gate and into the Bus Operations and Maintenance Facility.
  - c. Drop bags picked up from Location 2 (below).
  - d. Pick up prepared deposits for same day transport to Bank of America location (coins & cash bagged in compliance with the bank's protocol and requirements for accepting deposits from armored car services).
  - e. Pick up approximately 5-6 cash bags to go to Location 2 on the following scheduled delivery day (Number of bags may vary during a holiday week).
- B. Location 2: Vallejo Transit Center (VTC) at 311 Sacramento Street, Vallejo, CA
- a. Pick up and drop off between 10:00 a.m. – 4:00 p.m.
  - b. Mixed currency, tickets, small amount of coin.
  - c. Pick up bags for Location 1 (Above) (mixed currency, tickets, and small amount of coin, all in the same bags).
  - d. Drop off 5 or 6 bags picked up from Location 1 on the previous pick up day (Number of bags may vary during a week where a holiday is observed).

### **7.4 MOBILE VAULT PICK UP AND CURRENCY PROCESSING SERVICES**

- A. Pick up GFI mobile vault unit as part of each scheduled trip to 1850 Broadway. Vault will contain only cash and coin.

Vault Description:

- GFI Vault separates cash and coin into separate compartments
  - Vault is a mobile bin contained within a separate housing
- B. Contractor's personnel shall be required to:
- a. Count coins;
  - b. Count bills;
  - c. Deposit both types of currency in SolTrans' designated bank account (currently Bank of America) on regularly scheduled days.
- C. Contractor must provide a dedicated, secure, and video monitored room for cash counting, consistent with industry standard.
- D. Contractor must provide SolTrans with detailed reports of all currency and coin extracted from the mobile vault bin via email or fax within two (2) business days of mobile vault bin pick up.

- E. Contractor must complete deposits within three (3) calendar days from the date of collection.
- F. Cash counting methodology (following secure delivery to Contractor's cash counting location)
  - a. Currency (Bills)
    - 1. Ones: Fine Count/Weigh Processing
    - 2. All other denominations: Fine Count
  - b. Coin: Machine Sort/Piece Count
  - c. Unfit Currency: Fine Count
- G. Average currency & coin value per pick up which equates to 3 – 4 days of fare revenue collected
  - a. Note Count: 6,970                      Currency value: \$13,588.00
  - b. Coin Count: 10,463                      Coin value: \$1,961.00

**7.5 ANNUAL SCHEDULE**

- A. Scheduled pick up and drop off days are each Tuesday and Friday, excluding holidays. When a Tuesday or Friday falls on a holiday, the pick up and drop off will be scheduled for the next or prior business day at no additional charge. Pick up and drop off times are available from 8:00 a.m. – 4:00 p.m. at Location 1 and 10:00 a.m. – 4:00 p.m. at Location 2.
- B. The Contractor shall maintain a regular pick up time. Changes to pick up dates and times may be adjusted by SolTrans in cooperation with the Contractor. The Contractor shall also provide special on-call pick ups as requested by SolTrans.
- C. There will be no service, except by special request on the following days
  - a. Weekends
  - b. Holidays (New Year's Day, Martin Luther King Jr. Day, Presidents' Day, Memorial Day, Fourth of July, Labor Day, Thanksgiving, Christmas Day)

**7.6 LICENSE AND PERMITS**

- A. Contractor shall be licensed by the State of California to do all work required under this contract. Contractor shall obtain and maintain in current status all applicable permits and licenses required by law to perform the services under this contract.
- B. Contractor shall provide armed and bonded guards that have been trained and are experienced in armored car pick up and delivery service. Guards must be properly licensed by the State of California to carry a weapon. Guards must be uniformed, as well as wear and present identification at the pick up point.
- C. Contractor shall provide copies of all required licenses and permits to SolTrans' Finance & Administration Department annually upon renewal.

- D. Contractor shall provide evidence of insurance requirements in accordance with the sample standard contract in Appendix B.
- E. All items or services to be furnished hereunder shall meet all applicable state and federal requirements of the Occupational Safety and Health Standard.

## **7.7 PERSONNEL**

- A. Contractor shall provide two (2) personnel in a Contractor-furnished armored car that identifies Contractor's name.
- B. Contractor's assigned personnel providing services hereunder shall possess a valid California Driver's License with no more than one (1) moving violation during the past two (2) years. Personnel shall wear uniforms and carry and display an identification card. Such personnel shall be qualified, efficient, and trustworthy, bonded, and shall perform the service in accordance with the recognized best industry practices. All persons providing service under this contract shall be employees of Contractor and shall at all times be subject to the direct supervision and control of Contractor.

## **7.8 EQUIPMENT**

- A. All motor equipment vehicles used for services provided under the contract shall be properly "armored" and equipped for the service to be performed. No standard street vehicles such as non-armored automobiles, vans, light trucks shall be used. Only armored cars meeting the standards of the accepted industry definition of such vehicles will be acceptable. Vehicles must be equipped with two way communications. Each vehicle will be manned with two guards.
- B. Contractor shall submit evidence that all transport vehicles to be used are capable of carrying and securing one (1) GFI Mobile Vault bin with the dimensions and weight as identified in Appendix C: MOBILE VAULT BIN DIMENSIONS

## **7.9 MATERIALS AND LABOR**

Contractor shall furnish all required materials and labor for the services identified in this scope of work.

## **7.10 OTHER REQUIREMENTS**

### **7.10.1 CASH CONTROL**

- A. Contractor shall be required to pick up and deliver cash, coin and other revenue media on regularly scheduled days except Saturdays and Sundays and SolTrans holidays as indicated in Section 7.5 ANNUAL SCHEDULE unless notified otherwise. SolTrans reserves the right to add or delete locations or alter the schedule of pickups for service changes SolTrans deems necessary.
- B. Uncounted mobile vault cash may include unsorted bills, with coins separate from the bills. Any other items would be unanticipated items.

C. Contractor shall be liable to SolTrans for all currency and coin received from SolTrans.

### **7.10.2 KEY CONTROL**

A. SolTrans' Finance & Administration Manager will issue access control keys, codes, and passes required to perform contractual duties. Access control keys and passes must be returned to the Finance Officer when the contract has ended.

B. Contractor's management personnel must maintain and secure SolTrans' mobile vault bin keys at all times. All keys must be logged as to usage at the time of their use. All unused keys must be kept in a secured vault at all times when not being used on scheduled pick up and delivery days. All keys needing replacement due to discrepancies, loss, theft or damage must be reported to SolTrans' Finance & Administration Manager immediately. All damaged keys are to be returned to SolTrans upon receipt of the replacement key.

### **7.10.3 DAMAGE**

A. The contractor shall be held responsible for any breakage to SolTrans' equipment either through negligence or reckless acts of the contractor or contractor's employees while working on SolTrans' premises or while performing the contracted services specified in this RFP. The Contractor shall immediately notify SolTrans via email or phone should Contractor experience any problems with the normal operation of the mobile vault bin equipment. Repair or replacement costs shall be deducted from amounts owed to the Contractor.

## APPENDIX A: REQUIRED FORMS

**APPENDIX A: REQUIRED FORMS**

**FORM 1 – COST PROPOSAL**

The Proposer’s offer should be signed and attached to this form and include a Fixed Monthly Fee to provide Cash Collection, Armored Transportation, Mobile Vault Transport and Cash Counting Services for two SolTrans locations as described in the scope of services (including a price proposal for option term years). The price proposal should also provide the proposer’s schedule of industry standard unit pricing (i.e. per strap; per bag, per vault). Quantities relating to the currency processing/cash counting price proposal may vary.

Please review the Draft Standard Contract Compensation terms before submitting the Cost / Price Proposal.

Any other proposed fees / surcharges / taxes should be included in the Price / Cost Proposal, along with the methodology for their application.

The Price / Cost Proposal should also include a mockup of the first month’s invoice. If a fuel surcharge is being proposed, then use the previous month’s fuel price history to prepare an estimated additional cost to the fixed fee.

THE OFFEROR HEREBY ACKNOWLEDGES RECEIPT OF AND AGREES THAT IT HAS READ AND UNDERSTOOD THE ENTIRE PROPOSAL, AND ITS COST PROPOSAL IS BASED ON THE SCOPE OF WORK AND TERMS PROVIDED IN THE SOLICITATION AS MODIFIED BY THE FOLLOWING ADDENDA (IF ANY):

#1\_\_\_\_\_ #2\_\_\_\_\_ #3\_\_\_\_\_ #4\_\_\_\_\_ #5\_\_\_\_\_ (Please Initial)

IN COMPLIANCE WITH THIS SOLICITATION, THE UNDERSIGNED OFFEROR HAVING EXAMINED THE REQUEST FOR PROPOSAL AND BEING FAMILIAR WITH THE CONDITIONS TO BE MET, HEREBY SUBMITS THE ATTACHED. AN INDIVIDUAL AUTHORIZED TO BIND THE COMPANY MUST SIGN BELOW. FAILURE TO EXECUTE THIS PORTION MAY RESULT IN PROPOSAL REJECTION.

**Signature of Authorized Official:** \_\_\_\_\_ **Date:** \_\_\_\_\_

**Title:** \_\_\_\_\_

**Print Name:** \_\_\_\_\_

**APPENDIX A: REQUIRED FORMS**

**FORM 2 – NON-COLLUSION AFFIDAVIT FOR CONTRACTOR**

STATE OF CALIFORNIA

COUNTY OF SOLANO

\_\_\_\_\_ declares and says:

1. That he/she is the (owner, partner, representative, or agent) of \_\_\_\_\_, hereinafter referred to as (CONTRACTOR) or (SUBCONTRACTOR).
2. That he/she is fully informed regarding the preparation and contents of this proposal for certain work in SolTrans, State of California.
3. That his/her proposal is genuine and is not collusive or a sham proposal.
4. That any of its officers, owners, agents, representatives, employees, or parties in interest, including its affiliates, has not in any way colluded, conspired, connived or agreed, directly or indirectly, with any other CONTRACTOR, firm, or person to submit a collusive or sham proposal in connection with such contract or to refrain to submitting a proposal in connection with such contract, or has in any manner, directly or indirectly, sought by unlawful agreement or connivance with any other CONTRACTOR, firm, or person to fix the price or prices in said proposal, or to secure through collusion, conspiracy, connivance, or unlawful agreement any advantage against SolTrans or any person interested in the proposed contract; and,
5. That the price or prices quoted in the proposal are fair and proper and are not tainted by any collusion, conspiracy, connivance, or unlawful agreement on the part of the CONTRACTOR or any of its agents, owners, representatives, employees, or parties in interest, including its affiliate.

I certify (or declare) under penalty of perjury, that the foregoing is true and correct.

Dated this \_\_\_\_\_ day of \_\_\_\_\_, 2017 at \_\_\_\_\_, California.

Signed: \_\_\_\_\_

Title: \_\_\_\_\_



**APPENDIX A: REQUIRED FORMS**

**FORM 3 – CERTIFICATION OF PRIMARY PARTICIPANT REGARDING  
RESPONSIBILITY MATTERS**

The Primary Participant \_\_\_\_\_ (Name of CONTRACTOR) certifies to the best of its knowledge and belief, that it and its principals:

a. Have not within a three year period preceding this proposal been convicted or had a civil judgment rendered against them for commission of fraud or a criminal offense in connection with obtaining, attempting to obtain, or performing a public (Federal, state or local) transaction or contract under a public transaction; violation of Federal or state antitrust statutes or commission of embezzlement, theft, forgery, bribery, falsification or destruction of records, making false statements, or receiving stolen property;

b. Are not presently under indictment for or otherwise criminally or civilly charged by a governmental entity (Federal, state or local) with commission of any of the offenses enumerated in paragraph (a) of this certification; and

c. Have not within a three year period preceding this proposal had one or more public transactions or contracts (Federal, state or local) terminated for default.

If the primary participant is unable to certify to any of the statements in this certification, the participant shall attach an explanation to this certification.

THE PRIMARY PARTICIPANT, \_\_\_\_\_ (Name of CONTRACTOR) CERTIFIES OR AFFIRMS THE TRUTHFULNESS AND ACCURACY OF THE CONTENTS OF THE STATEMENTS SUBMITTED ON OR WITH THIS CERTIFICATION AND UNDERSTANDS THAT THE PROVISIONS OF 31 USC SECTIONS 3801 ET SEQ. ARE APPLICABLE THERETO.

\_\_\_\_\_  
Signature of Authorized Official

\_\_\_\_\_  
Title

The undersigned chief legal counsel (or corporate secretary) for the \_\_\_\_\_ certifies that the \_\_\_\_\_ has authority under state and local law to comply with the subject assurances and that the certification above has been legally made.

\_\_\_\_\_  
Signature of Attorney/Secretary

\_\_\_\_\_  
Date

**APPENDIX A: REQUIRED FORMS**

**FORM 4 – LISTING OF SUBCONTRACTORS**

The CONTRACTOR declares that it has contacted the subcontractors listed below, and has made arrangements covering hourly rates and other terms which may materially affect the Contract, contingent upon successfully entering into a contract with SolTrans, with the following subcontractors:

	<b>Name/Address of Subcontractor</b>	<b>DBE? yes/no</b>	<b>Amount of Subcontract</b>	<b>Description of Work</b>
1.				
2.				
3.				
4.				
5.				
6.				

**NOTE:** The above DBE/EEO Affidavit is part of CONTRACTOR'S Proposal. Signing this Proposal on the signature portion thereof shall also constitute signature of this DBE/EEO Affidavit.

\_\_\_\_\_  
SIGNATURE

\_\_\_\_\_  
DATE

\_\_\_\_\_  
TITLE

\_\_\_\_\_  
COMPANY NAME

## APPENDIX A: REQUIRED FORMS

### FORM 5 – CONTRACTOR QUESTIONNAIRE

Proposers and their subconsultants must complete the Vendor Registration & Addenda Request Form [HERE](#)<sup>1</sup>.

If any Proposer has difficulty using or accessing the form above, please contact (707) 736-6990 or email [larry@soltransride.com](mailto:larry@soltransride.com) by 4:00 P.M. PST Tuesday November 21, 2017 for assistance.

---

<sup>1</sup><http://www.soltransride.com/about/doing-business-with-soltrans/vendor-registration-form/>

## **APPENDIX B: SOLTRANS STANDARD CONTRACT**

SolTrans Standard Contract is attached as APPENDIX B. It is not formatted like the rest of the RFP, and has been incorporated as a “Stand Alone” PDF document into the RFP. In limited circumstances SolTrans may, but is not bound, to make changes to the Standard Contract. Any requested changes to the contract must be addressed prior to submission of the proposal. Conditional proposals are not typically accepted, and may be rejected as non-responsive to the proposal. Reviewing the standard contract is important, and proposers will be bound by their submission, under the terms of this standard contract.

**Solano County Transit - SolTrans  
Standard Professional Services Contract  
Project: [Enter Solicitation Title]**

---

1. **Project Description: Comprehensive Operational Analysis**
2. **This Contract is entered into between the Solano County Transit (SolTrans) and the Contractor named below:**  
  
Contractor's Name: [successful proposer]                      Business Form: [organization form]
3. **The Term of this Contract is: From date of execution of contract to [termination date].**
4. **The maximum amount of this Contract is: [Not to Exceed Amount]**
5. **The CONTRACTOR agrees to comply with the terms and conditions of the following exhibits which are by this reference made a part of this Contract and incorporated herein as though set forth in full:**
  - **Exhibit A – Scope of Work**
  - **Exhibit B – Budget Detail and Payment Provisions**
  - **Exhibit C – General Terms and Conditions**

**IN CONSIDERATION OF THE MUTUAL PROMISES CONTAINED IN THIS CONTRACT, THE PARTIES HAVE EXECUTED THIS CONTRACT ON THE \_\_\_ DAY OF \_\_\_\_\_, 2017.**

**SOLANO COUNTY TRANSIT**

**CONTRACTOR**

By \_\_\_\_\_  
**BETH KRANDA, Executive Director**

By \_\_\_\_\_  
[Company signature authority], [title]

**Approved as to form:**

By: \_\_\_\_\_  
**BERNADETTE CURRY, SolTrans Legal Counsel**

**SolTrans Contact Information**

Beth Kranda, Executive Director  
SolTrans  
311 Sacramento St.  
Vallejo, CA 94590  
Attn: Michael Abegg  
Telephone: (707) 736-6983

**Contractor Contact Information**

[Contractor Project Manager]  
[Company Contact Street Address]  
[Company Contact City, State, CIP]  
[Company Contact Phone]  
[Company Contact Email]

**CONTRACT MUST BE EXECUTED BEFORE WORK CAN COMMENCE**

**Solano County Transit - SolTrans  
Standard Professional Services Contract  
Project: [Enter Solicitation Title]**

**EXHIBIT A**

**SCOPE OF WORK**

**1. Specified Documents.**

Contractor shall perform those services specified in detail here. Contractor's services are described in various attachments and exhibits, each of which is incorporated into this Contract by this reference which define and describe the Project to be undertaken by Contractor. SolTrans has materially relied upon the representations of Contractor as may have been made in SolTrans' selection of Contractor for this Project. Contractor agrees to perform or secure the performance of all specified services in their entirety within the maximum payment specified herein. Said Scope of Services consists of, and includes, the following documents:

- a. SolTrans Staff Report to SolTrans Board Dated [staff report date], and approved by SolTrans Board on [Board Action];
- b. SolTrans' Solicitation: [Enter Solicitation Title];
- c. Contractor's written response to the Solicitation dated [Date of accepted proposal];
- d. Contractor's Cost Proposal; and, further all statements and representations of Contractor made during their presentation to SolTrans' selection board and thereafter to the officers and employees of SolTrans who have participated in the determination to contract with Contractor for this Project. Those documents, presentations and discussions are material representations upon which SolTrans has relied in selecting and contracting with Contractor and shall be utilized in any matter in which interpretation of this Contract is required.

**2. General Scope of Work**

General Scope of the RFP

**3. Tasks**

**4. Deliverables**

**Solano County Transit - SolTrans  
Standard Professional Services Contract  
Project: [Enter Solicitation Title]**

**EXHIBIT B**

**BUDGET DETAIL AND PAYMENT PROVISIONS**

- A. Compensation.** This is a “not to exceed” contract. Contractor shall be paid, as full compensation for the satisfactory completion of the work, in amount not to exceed [Not to Exceed Amount], as set forth on Contractor’s “Cost/Fee Proposal” which includes all applicable surcharges such as taxes, insurance, and fringe benefits, as well as indirect costs, overhead and profit allowance, subcontractor’s costs, travel, materials and supplies.
- B. Progress Payments.** Payment for Contractor’s services shall be due in the amounts agreed upon, if any, upon acceptance by Project Manager of those deliverables marking completion of a particular portion or period of the Project and as invoiced in accordance with Contractor’s proposal.
- C. Maximum Payment.** Subject only to duly executed amendments, it is expressly understood and agreed that in no event will the total compensation to be paid Contractor under this Contract exceed the sums set forth herein unless pursuant to written amendment of this Contract approved by SolTrans Board.
- D. Method of Payment.** Contractor shall submit an invoice identifying the Project deliverable or milestone, along with a brief status statement of the Study’s progress to date for which payment is sought, no later than thirty days after SolTrans’ acceptance of such deliverable/milestone. SolTrans shall endeavor to make payments within thirty (30) days of receipt of an acceptable invoice, approved by the Project Manager or a designated representative. All invoices shall be made in writing and delivered or mailed to the SolTrans Project Manager as follows:
- Accounts Payable  
SolTrans  
311 Sacramento St.  
Vallejo, CA 94590  
Attn: [SOLTRANS PROJECT MANAGER]
- E. Cost/Fee Proposal** If Contractor has submitted a written Cost/Fee Proposal or Summary, that document is attached as Attachment 1 to Exhibit B and incorporated into this Exhibit as though set forth in full.

Unless Milestone payments are established in the Contractors Cost/Fee Proposal or Summary, Contractor shall invoice no more often than every month, and shall set forth in the invoice the hours worked, progress made, and provide adequate documentation regarding materials utilized during performance of the work.

Travel time to any SolTrans worksite in the Cities of Vallejo and Benicia will not be paid to the Contractor, and any related overhead should be figured into the total hourly rate. Mileage (at the then current IRS rate) and travel time and reasonable expenses will be paid for any travel agreed to in advance by SolTrans, and should be included in the invoice.

**Solano County Transit - SolTrans  
Standard Professional Services Contract  
Project: [Enter Solicitation Title]**

**EXHIBIT C**

**GENERAL TERMS AND CONDITIONS**

**1. Conflict With Caltrans Or Federal Provisions**

In those circumstances where Caltrans or Federal funds are involved, those Caltrans or Federal provisions shall control over a General Term or Condition.

**2. Closing out**

SolTrans will pay Contractor's final invoice for payment providing Contractor has completed all obligations undertaken pursuant to this Contract. Contractor is responsible for SolTrans' receipt of a final invoice for payment 60 days after termination or completion of this Contract.

**3. Time**

Time is of the essence in all terms and conditions of this Contract.

**4. Time of Performance**

Work will not begin, nor claims paid for services under this Contract until all Certificates of Insurance, business and professional licenses/certificates, IRS ID number, signed W-9 form, or other applicable licenses or certificates are on file with SolTrans' Contract Manager.

**5. Termination**

- A. This Contract may be terminated by SolTrans or Contractor, at any time, with or without cause, upon 30 days written notice from one to the other, unless otherwise provided for elsewhere in the Contract.
- B. SolTrans may terminate this Contract immediately upon notice of Contractor's malfeasance.
- C. Following termination, SolTrans will reimburse Contractor for all expenditures made in good faith that are unpaid at the time of termination not to exceed the maximum amount payable under this Contract unless Contractor is in default of the Contract.

**6. Signature Authority**

The parties executing this Contract certify that they have the proper authority to bind their respective entities to all terms and conditions set forth in this Contract.

**7. Warranty**

- A. SolTrans relies upon Contractor's professional ability and training as a material inducement to enter into this Contract. Contractor warrants that Contractor will perform the work according to generally accepted professional practices and standards and the requirements of applicable federal, state and local laws. SolTrans' acceptance of Contractor's work shall not constitute a waiver or release of Contractor from professional responsibility.
- B. Contractor further warrants that Contractor possesses current valid appropriate licensure, including, but not limited to, drivers license, professional license, certificate of tax-exempt status, or permits, required to perform the work under this Contract.



**Solano County Transit - SolTrans  
Standard Professional Services Contract  
Project: [Enter Solicitation Title]**

**8. Best Efforts**

Contractor warrants that Contractor will, at all times, faithfully, industriously and to the best of his/her/its ability, experience and talent, perform to SolTrans' reasonable satisfaction.

**9. Default**

- A. If Contractor defaults in Contractor's performance, SolTrans shall promptly notify Contractor in writing. If Contractor fails to cure a default within 30 days after notification, or if the default requires more than 30 days to cure and Contractor fails to commence to cure the default within 30 days after notification, then Contractor's failure shall terminate this Contract.
- B. If Contractor fails to cure default within the specified period of time, SolTrans may elect to cure the default and any expense incurred shall be payable by Contractor to SolTrans.
- C. If SolTrans serves Contractor with a notice of default and Contractor fails to cure the default, Contractor waives any further notice of termination of this Contract.
- D. If this Contract is terminated because of Contractor's default, SolTrans shall be entitled to recover from Contractor all damages allowed by law.

**10. Indemnification**

Contractor shall indemnify and hold harmless SolTrans, its officers, officials, employees and volunteers from and against all actions, causes of actions, damages, costs, liabilities, claims, losses, judgments, penalties and expenses of every type and description, including without limitation any fees and/or costs reasonably incurred by SolTrans' staff attorneys or contract attorneys and any and all costs, fees and expenses incurred in enforcing this provision (hereafter collectively referred to as "liabilities"), arising out of or in connection with any negligent act or omission, misconduct or other legal fault of Contractor, its officers, employees, sub-contractors, subcontractors or agents in connection with the performance or nonperformance of this Contract, whether or not SolTrans accepted or approved any service or work product performed or provided by Contractor hereunder, and whether or not such liabilities are litigated, settled or reduced to judgment. In the event that a final decision or judgment allocates liability by determining that any portion of damages awarded is attributable to SolTrans' negligence or willful misconduct, SolTrans shall pay the portion of damages which is allocated to SolTrans' negligence or willful misconduct, provided that SolTrans shall not be liable for any passive negligence of SolTrans, its officers, officials, employees and volunteers in reviewing, accepting or approving any service or work product performed or provided by Contractor.

Contractor shall, upon SolTrans' request, defend with counsel approved by SolTrans (which approval shall not be unreasonably withheld), at Contractor's sole cost and expense, any action, claim, suit, cause of action or portion thereof which asserts or alleges liabilities resulting from any allegedly negligent act, omission, misconduct or other legal fault of Contractor, its officers, employees, sub-contractors, subcontractors or agents in connection with the performance or nonperformance of this Contract, whether or not such action, claim, suit, cause of action or portion thereof is well founded or lacking in merit.

Acceptance of insurance certificates or endorsements required under this Contract does not relieve Contractor from liability under this Section 10 and shall apply to all damages and claims of every kind suffered, or alleged to have been suffered, by reason of Contractor's negligence, misconduct, or other legal fault regardless of whether or not such insurance policies shall have been determined

**Solano County Transit - SolTrans  
Standard Professional Services Contract  
Project: [Enter Solicitation Title]**

to be applicable to any of such damages or claims for damages. The provisions of this Section shall survive any termination of this Contract.

**11. Insurance Requirements**

Contractor shall procure and maintain for the duration of this Contract the following insurance:

**Minimum Scope of Insurance:**

Coverage shall be at least as broad as:

1. Insurance Services Office Commercial General Liability coverage ("occurrence" form CG 0001).
2. Insurance Services Office form number CA 0001 (Ed. 1/87) covering Automobile Liability, code 1 (any auto). If Contractor owns no vehicles, this requirement may be satisfied by a non-owned auto endorsement to the general liability policy described above. If Contractor or Contractor's employees will use personal autos in any way on this project, Contractor shall obtain evidence of personal auto liability coverage for each person.
3. Workers' Compensation insurance as required by the State of California and Employer's Liability insurance.
4. Errors and Omissions liability insurance appropriate to the Contractor's profession. Architect's and engineers' coverage is to be endorsed to include contractual liability.

**Minimum Limits of Insurance:**

CONTRACTOR shall maintain limits no less than:

1. General Liability: \$2,000,000 per occurrence for bodily injury, personal injury and property damage. If Commercial General Liability Insurance or other form with a general aggregate limit is used, either the general aggregate limit shall apply separately to this location or the general aggregate limit shall be twice the required occurrence limit.
2. Automobile Liability: \$2,000,000 per accident for bodily injury and property damage, combined single limit.
3. Employer's Liability: \$2,000,000 per accident for bodily injury or disease, and in the aggregate.
4. Errors and Omissions Liability: \$1,000,000 on a claims made basis.

**Deductibles and Self-Insurance Retentions:**

Any deductibles or self-insured retentions exceeding \$50,000 must be declared to and approved by SolTrans. At the option of SolTrans, either: the Contractor shall reduce or eliminate such deductibles or self-insured retentions with respect to SolTrans, its officers, officials, employees and volunteers; or Contractor shall provide a financial guarantee satisfactory to SolTrans guaranteeing payment of losses and related investigations, claim administration and defense expenses.

**Solano County Transit - SolTrans  
Standard Professional Services Contract  
Project: [Enter Solicitation Title]**

**Other Insurance Provisions:**

The general liability and automobile liability policies are to contain, or be endorsed to contain, the following provisions:

1. SolTrans, its officers, officials, employees and volunteers are to be covered as insureds with respect to the liability arising out of automobiles owned, leased, hired or borrowed by or on behalf of the Contractor, and with respect to liability arising out of work or operations by or on behalf of the Contractor including materials, parts or equipment furnished in connection with such work or operations. General liability coverage can be provided in the form of an endorsement to the Contractor's insurance or as a separate owner's policy.
2. For any claims related to this project, the Contractor's insurance coverage shall be primary insurance as respects SolTrans, its officers, officials, employees, and volunteers. Any insurance or self-insurance maintained by SolTrans, its officers, officials, employees and volunteers shall be excess of the Contractor's insurance and shall not contribute with it.
3. Should the above described policies be cancelled prior to the policies' expiration date, Contractor agrees that notice of cancellation will be delivered under the policy provisions.

**Acceptability of Insurers:**

Insurance is to be placed with insurers with a current A.M. Best's rating of no less than A:VII, unless otherwise acceptable to SolTrans.

**Verification of Coverage:**

Contractor shall furnish SolTrans with original certificate and amendatory endorsements effecting coverage required by this clause. The endorsements should be on forms provided by SolTrans or on other than SolTrans' forms, provided those endorsements or policies conform to the requirements stated in this clause. All certificates and endorsements are required to be received and approved by SolTrans before work commences. SolTrans reserves the right to require complete, certified copies of all required insurance policies, including endorsements effecting coverage required by these specifications at any time.

**All insurance documents are to be sent to:**

SolTrans  
Attn: SolTrans Legal Counsel  
311 Sacramento St.  
Vallejo, CA 94590

**Sub-Contractors:**

Contractor shall include all sub-contractors as insureds under its policies or shall furnish separate certificates and endorsements for each sub-contractor. All coverages for sub-contractors shall be subject to all of the requirements stated above unless specifically waived by SolTrans in writing.

**Solano County Transit - SolTrans  
Standard Professional Services Contract  
Project: [Enter Solicitation Title]**

**Forms of Endorsement:**

Endorsements shall include the following provisions. SolTrans understands and agrees that variations in language may occur:

THIS ENDORSEMENT, EFFECTIVE \_\_\_\_\_ A.M. \_\_\_\_\_,  
201\_\_, FOR POLICY NUMBER \_\_\_\_\_, IS ISSUED TO THE  
SOLANO COUNTY TRANSIT BY \_\_\_\_\_  
FOR (PROJECT DESCRIPTION OR  
TITLE)\_\_\_\_\_.

**ADDITIONAL INSURED**

IT IS UNDERSTOOD AND AGREED THAT SOLTRANS, ITS OFFICERS,  
OFFICIALS, EMPLOYEES AND VOLUNTEERS ARE NAMED AS ADDITIONAL  
INSUREDS ON THE GENERAL AND AUTOMOTIVE LIABILITY INSURANCES.

**PRIMARY INSURANCE**

IT IS FURTHER UNDERSTOOD AND AGREED THAT THE INSURANCE  
AFFORDED BY THIS POLICY SHALL BE CONSIDERED PRIMARY INSURANCE  
AS RESPECTS ANY OTHER VALID AND COLLECTIBLE INSURANCE  
SOLTRANS MAY POSSESS, INCLUDING ANY SELF INSURED RETENTION  
SOLTRANS MAY HAVE, AND ANY OTHER INSURANCE SOLTRANS DOES  
POSSESS SHALL BE CONSIDERED EXCESS INSURANCE ONLY.

**CANCELLATION CLAUSE**

WRITTEN NOTICE OF CANCELLATION SHALL BE GIVEN TO SOLTRANS IN  
THE EVENT OF CANCELLATION AND/OR REDUCTION IN COVERAGE OF  
ANY NATURE. SUCH NOTICE SHALL BE SENT TO:

SolTrans  
Attn: SolTrans Legal Counsel  
311 Sacramento St.  
Vallejo, CA 94590

THIS PARAGRAPH SUPERSEDES THE CANCELLATION CLAUSE IN THE  
CERTIFICATE OF INSURANCE.

ALL OTHER TERMS AND CONDITIONS OF THIS POLICY REMAIN  
UNCHANGED.

\_\_\_\_\_  
Authorized Representative

**12. Independent Contractor**

- A. Contractor is an independent contractor and not an agent, officer or employee of SolTrans. The parties mutually understand that this Contract is by and between two independent contractors and is not intended to and shall not be construed to create the relationship of agent, servant, employee,

**Solano County Transit - SolTrans  
Standard Professional Services Contract  
Project: [Enter Solicitation Title]**

partnership, joint venture or association.

- B. Contractor shall have no claim against SolTrans for employee rights or benefits including, but not limited to, seniority, vacation time, vacation pay, sick leave, personal time off, overtime, medical, dental or hospital benefits, retirement benefits, Social Security, disability, Workers' Compensation, unemployment insurance benefits, civil service protection, disability retirement benefits, paid holidays or other paid leaves of absence.
- C. Contractor is solely obligated to pay all applicable taxes, deductions and other obligations including, but not limited to, federal and state income taxes, withholding, Social Security, unemployment, disability insurance, Workers' Compensation and Medicare payments. Contractor shall indemnify and hold SolTrans harmless from any liability which SolTrans may incur because of Contractor's failure to pay such obligations.
- D. As an independent contractor, Contractor is not subject to the direction and control of SolTrans except as to the final result contracted for under this Contract. SolTrans may not require Contractor to change Contractor's manner of doing business, but may require redirection of efforts to fulfill this Contract.
- E. Contractor may provide services to others during the same period Contractor provides service to SolTrans under this Contract.
- F. Any third persons employed by Contractor shall be under Contractor's exclusive direction, supervision and control. Contractor shall determine all conditions of employment including hours, wages, working conditions, discipline, hiring and discharging or any other condition of employment.
- G. As an independent contractor, Contractor shall indemnify and hold SolTrans harmless from any claims that may be made against SolTrans based on any contention by a third party that an employer-employee relationship exists under this Contract.
- H. Contractor, with full knowledge and understanding of the foregoing, freely, knowingly, willingly and voluntarily waives the right to assert any claim to any right or benefit or term or condition of employment insofar as they may be related to or arise from compensation paid hereunder.

**13. Commitment Of Key Contractor Personnel**

In recognition of the special skill of Contractor's proposed "Project Team", if such a team has been proposed, SolTrans has relied upon the commitment by Contractor of certain key personnel assigned to this work by Contractor as well as an estimate of the commitment of their time to this Project, all as set forth in Contractor's Proposal found in Exhibit B. Substitution of any key personnel named in Exhibit A or a decrease in the commitment of time to be provided to the Project by such personnel of more than 10% requires the prior written approval of SolTrans. Contractor shall maintain records documenting compliance with this Article, which shall be subject to the audit requirements herein.

**14. Responsibilities of Contractor**

- A. The parties understand and agree that Contractor possesses the requisite skills necessary to perform the work under this Contract and SolTrans relies upon such skills. Contractor pledges to perform the work skillfully and professionally. SolTrans' acceptance of Contractor's work does not constitute a release of Contractor from professional responsibility.

**Solano County Transit - SolTrans  
Standard Professional Services Contract  
Project: [Enter Solicitation Title]**

- B. Contractor verifies that Contractor has reviewed the scope of work to be performed under this Contract and agrees that in Contractor's professional judgment, the work can and shall be completed for costs within the maximum amount set forth in this Contract.
- C. To fully comply with the terms and conditions of this Contract, Contractor shall:
  - 1. Establish and maintain a system of accounts for budgeted funds that complies with generally accepted accounting principles for government agencies;
  - 2. Document all costs by maintaining complete and accurate records of all financial transactions associated with this Contract, including, but not limited to, invoices and other official documentation that sufficiently support all charges under this Contract;
  - 3. Submit monthly reimbursement claims for expenditures that directly benefit SolTrans;
  - 4. Along with monthly reimbursement claims contractor will submit their listing of subcontractors identifying the subtotaled portion of the claim that will be sent to each subcontractor and a running total of the total amounts paid to date to each subcontractor.
  - 5. Be liable for repayment of any disallowed costs identified through quarterly reports, audits, monitoring or other sources; and
  - 6. Retain financial, programmatic, client data and other service records for 4 years from the date of the end of the contract award or for 4 years from the date of termination, whichever is later.

**15. Compliance with Law**

- A. Contractor shall comply with all federal, state and local laws and regulations applicable to Contractor's performance, including, but not limited to, licensing, employment and purchasing practices, wages, hours and conditions of employment.
- B. Contractor warrants that all Contractor claims for payment or reimbursement by SolTrans will comply with the applicable Office of Management and Budget Circulars, particularly with respect to 2 CFR Part 225 and 2 CFR Part 230, as currently enacted or as may be amended throughout the term of this Contract.

**16. Confidentiality**

- A. Contractor shall prevent unauthorized disclosure of names and other SolTrans-identifying information, except for statistical information not identifying a particular project.
- B. Contractor shall not use SolTrans-specific information for any purpose other than carrying out Contractor's obligations under this Contract.
- C. Contractor shall promptly transmit to SolTrans all requests for disclosure of confidential information.
- D. Except as otherwise permitted by this Contract or authorized by SolTrans, Contractor shall not disclose any confidential information to anyone other than the State without prior written authorization from SolTrans.
- E. For purposes of this section, identity shall include, but not be limited to, name, identifying number, symbol or other client identifying particulars, such as fingerprints, voice print or photograph.

**Solano County Transit - SolTrans  
Standard Professional Services Contract  
Project: [Enter Solicitation Title]**

**17. Conflict of Interest**

- A. Contractor warrants that Contractor and/or Contractor's employees and/or their immediate families and/or Board of Directors and/or officers have no interest, including, but not limited to, other projects or independent contracts, and shall not acquire any interest, direct or indirect, including separate contracts for the work to be performed hereunder, which conflicts with the rendering of services under this Contract. Contractor shall employ or retain no such person while rendering services under this Contract. Services rendered by Contractor's associates or employees shall not relieve Contractor from personal responsibility under this clause.
- B. Contractor has an affirmative duty to disclose to SolTrans in writing the name(s) of any person(s) who have an actual, potential or apparent conflict of interest.

**18. Drug Free Workplace**

Contractor warrants that Contractor is knowledgeable of Government Code section 8350 et seq., regarding a drug free workplace and shall abide by and implement its statutory requirements.

**19. Health and Safety Standards**

Contractor shall abide by all health and safety standards set forth by the State of California and/or the SolTrans pursuant to the Injury and Illness Prevention Program. If applicable, Contractor must receive all health and safety information and training.

**20. Audits and Inspection of Record**

- A. Contractor shall permit SolTrans and its/their authorized representatives to have access to Contractor's books, records, accounts, and any and all work products, materials, and other data relevant to this Contract, including Contractor's place of business, for the purpose of making an audit, examination, excerpt and transcription during the term of this Contract and for a period of four (4) years thereafter. Contractor shall in no event dispose of, destroy, alter, or mutilate said books, records, accounts, work products, materials and data for that period of time.
- B. Contractor further agrees to include in all its subcontracts hereunder a provision to the effect that the subcontractor agrees that SolTrans or any of its/their duly authorized representatives shall have access to and the right to examine any directly pertinent books, documents, papers, and records of such subcontractor for the term of this Contract.
- C. The State, the State Auditor, SolTrans, Federal Highway Administration (FHWA), or any duly authorized representative of the federal government shall have access to any books, records and documents of the Contractor that are pertinent to the contract for audit, examination, excerpts, and transactions, and copies thereof shall be furnished if requested. This provision shall be applicable to subcontractors.

**21. Nondiscrimination**

- A. In rendering services under this Contract, Contractor shall comply with all applicable federal, state and local laws, rules and regulations and shall not discriminate based on age, ancestry, color, gender, marital status, medical condition, national origin, physical or mental disability, race, religion, sexual orientation, or other protected status.
- B. Further, Contractor shall not discriminate against its employees, which includes, but is not limited to, employment upgrading, demotion or transfer, recruitment or recruitment advertising, layoff or

**Solano County Transit - SolTrans  
Standard Professional Services Contract  
Project: [Enter Solicitation Title]**

termination, rates of pay or other forms of compensation and selection for training, including apprenticeship.

**22. Subcontractor and Assignment**

- A. Services under this Contract are deemed to be personal services.
- B. Contractor shall not subcontract any work under this Contract nor assign this Contract or monies due without the prior written consent of SolTrans' Contract Manager, subject to any required state or federal approval.
- C. If SolTrans consents to the use of Subcontractors, Contractor shall require and verify that its subcontractors maintain insurance meeting all the requirements stated in Section 11 above.
- D. Assignment by Contractor of any monies due shall not constitute an assignment of the Contract.

**23. Unforeseen Circumstances**

Contractor is not responsible for any delay caused by natural disaster, war, civil disturbance, labor dispute or other cause beyond Contractor's reasonable control, provided Contractor gives written notice to SolTrans of the cause of the delay within 10 days of the start of the delay.

**24. Ownership of Documents**

- A. SolTrans shall be the owner of and shall be entitled to possession of any computations, plans, correspondence or other pertinent data and information gathered by or computed by Contractor prior to termination of this Contract by SolTrans or upon completion of the work pursuant to this Contract.
- B. No material prepared in connection with the project shall be subject to copyright in the United States or in any other country.

**25. Notice**

- A. Any notice necessary to the performance of this Contract shall be given in writing by personal delivery or by prepaid first-class mail addressed as stated on the first page of this Contract.
- B. If notice is given by personal delivery, notice is effective as of the date of personal delivery. If notice is given by mail, notice is effective as of the day following the date of mailing or the date of delivery reflected upon a return receipt, whichever occurs first.

**26. Nonrenewal**

Contractor acknowledges that there is no guarantee that SolTrans will renew Contractor's services under a new contract following expiration or termination of this Contract. Contractor waives all rights to notice of non-renewal of Contractor's services.

**27. SolTrans' Obligation Subject to Availability of Funds**

- A. SolTrans' obligation under this Contract is subject to the availability of authorized funds. SolTrans may terminate the Contract, or any part of the Contract work, without prejudice to any right or



**Solano County Transit - SolTrans  
Standard Professional Services Contract  
Project: [Enter Solicitation Title]**

remedy of SolTrans, for lack of appropriation of funds. If expected or actual funding is withdrawn, reduced or limited in any way prior to the expiration date set forth in this Contract, or any subsequent Amendment, SolTrans may, upon written Notice to the Contractor, terminate this Contract in whole or in part.

- B. Payment shall not exceed the amount allowable for appropriation by the SolTrans Board. If the Contract is terminated for non-appropriation:
  - i. SolTrans will be liable only for payment in accordance with the terms of this Contract for services rendered prior to the effective date of termination; and
  - ii. The Contractor shall be released from any obligation to provide further services pursuant to this Contract that are affected by the termination.
- C. Funding for this Contract beyond the current appropriation year is conditional upon appropriation by the SolTrans Board of sufficient funds to support the activities described in this Contract. Should such an appropriation not be approved, this Contract will terminate at the close of the current Appropriation Year.
- D. This Contract is void and unenforceable if all or part of federal or State funds applicable to this Contract are not available to SolTrans. If applicable funding is reduced, SolTrans may either:
  - (1) Cancel this Contract; or,
  - (2) Offer a contract amendment reflecting the reduced funding.

**28. Changes and Amendments**

- A. SolTrans may request changes in Contractor's scope of services. Any mutually agreed upon changes, including any increase or decrease in the amount of Contractor's compensation, shall be effective when incorporated in written amendments to this Contract.
- B. The party desiring the revision shall request amendments to the terms and conditions of this Contract in writing. Any adjustment to this Contract shall be effective only upon the parties' mutual execution of an amendment in writing.
- C. No verbal Contracts or conversations prior to execution of this Contract or requested Amendment shall affect or modify any of the terms or conditions of this Contract unless reduced to writing according to the applicable provisions of this Contract.

**29. Choice of Law**

The parties have executed and delivered this Contract in the County of Solano, State of California. The laws of the State of California shall govern the validity, enforceability or interpretation of this Contract. Solano County shall be the venue for any action or proceeding, in law or equity that may be brought in connection with this Contract.

**30. Waiver**

Any failure of a party to assert any right under this Contract shall not constitute a waiver or a termination of that right, under this Contract or any provision of this Contract.

**31. Conflicts in the Contract Documents**

The Contract documents are intended to be complementary and interpreted in harmony so as to avoid conflict. In the event of conflict in the Contract documents, the parties agree that the document providing the highest quality and level of service to SolTrans shall supersede any

**Solano County Transit - SolTrans  
Standard Professional Services Contract  
Project: [Enter Solicitation Title]**

inconsistent term in these documents.

**32. Disbarment or Suspension of Contractor**

- A. Contractor warrants that its officers, directors and employees (i) are not currently excluded, debarred, or otherwise ineligible to participate in state or federal transportation related projects and programs; (ii) have not been convicted of a criminal offense related to the provision of consultant services but have not yet been excluded, debarred, or otherwise declared ineligible to participate in state or federal transportation related programs or projects, and (iii) are not, to the best of its knowledge, under investigation or otherwise aware of any circumstances which may result in Contractor being excluded from participation in state or federal transportation related projects or programs.
- B. This representation and warranty shall be an ongoing representation and warranty during the term of this Contract and Contractor must immediately notify SolTrans of any change in the status of the representations and warranty set forth in this section.

**33. Execution in Counterparts; Signatures by Facsimile or PDF**

This Contract may be executed in duplicate originals, each of which is deemed to be an original, but when taken together shall constitute one instrument. Facsimile copies or copies delivered via e-mail as a portable document format (pdf) file shall be deemed to be original copies.

**34. Entire Contract**

This Contract, including any exhibits referenced, constitutes the entire agreement between the parties and there are no inducements, promises, terms, conditions or obligations made or entered into by SolTrans or Contractor other than those contained.

## APPENDIX C: MOBILE VAULT DIMENSIONS

## A2. SUBSYSTEM COMPONENTS

Figure A2-1 shows the overall view of the revenue collection system. The revenue collection system consists of three major assemblies: the Mobile Bin Housing, the Receiver, and the Mobile Bin.

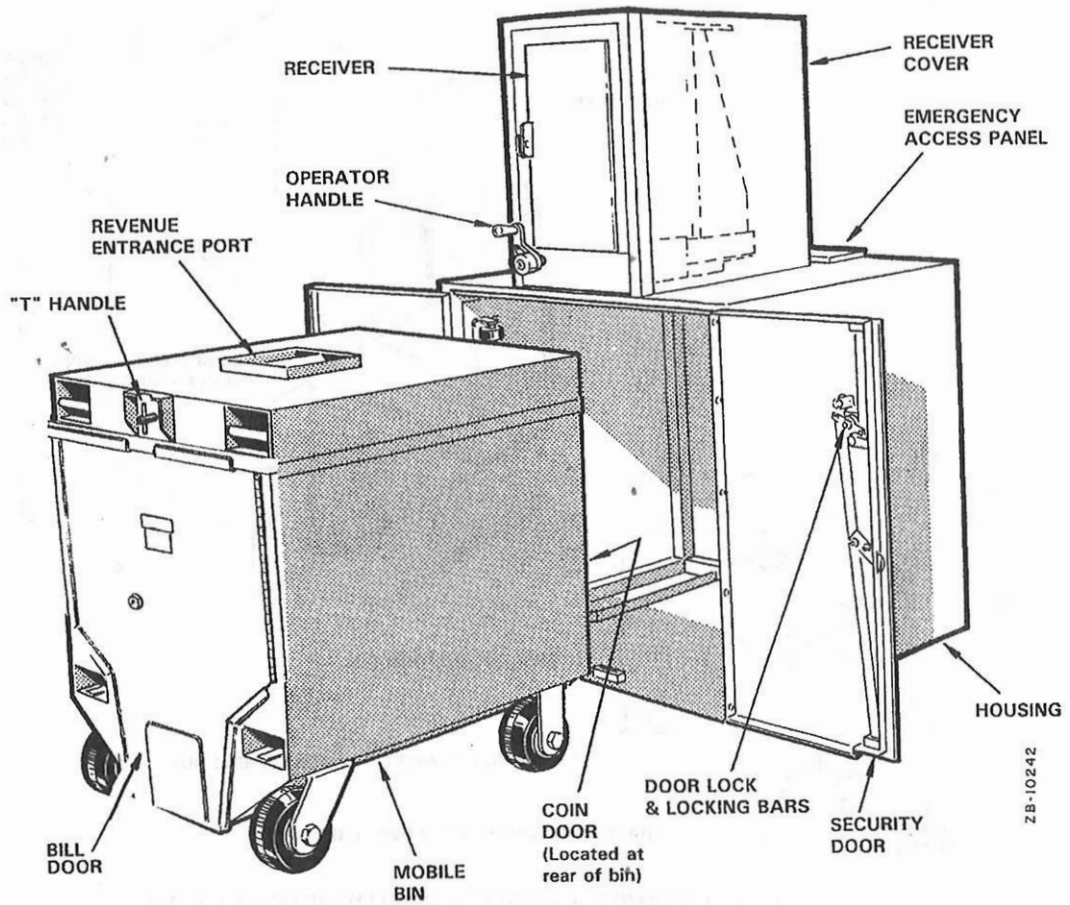

Figure A2-1.  
Mobile Revenue Collection System

# APPENDIX C: MOBILE VAULT DIMENSIONS

Figure A2-2 shows the dimensions for the receiver, housing, and bin.

## ENVELOPE DIMENSIONS FOR RECEIVER, HOUSING AND BIN

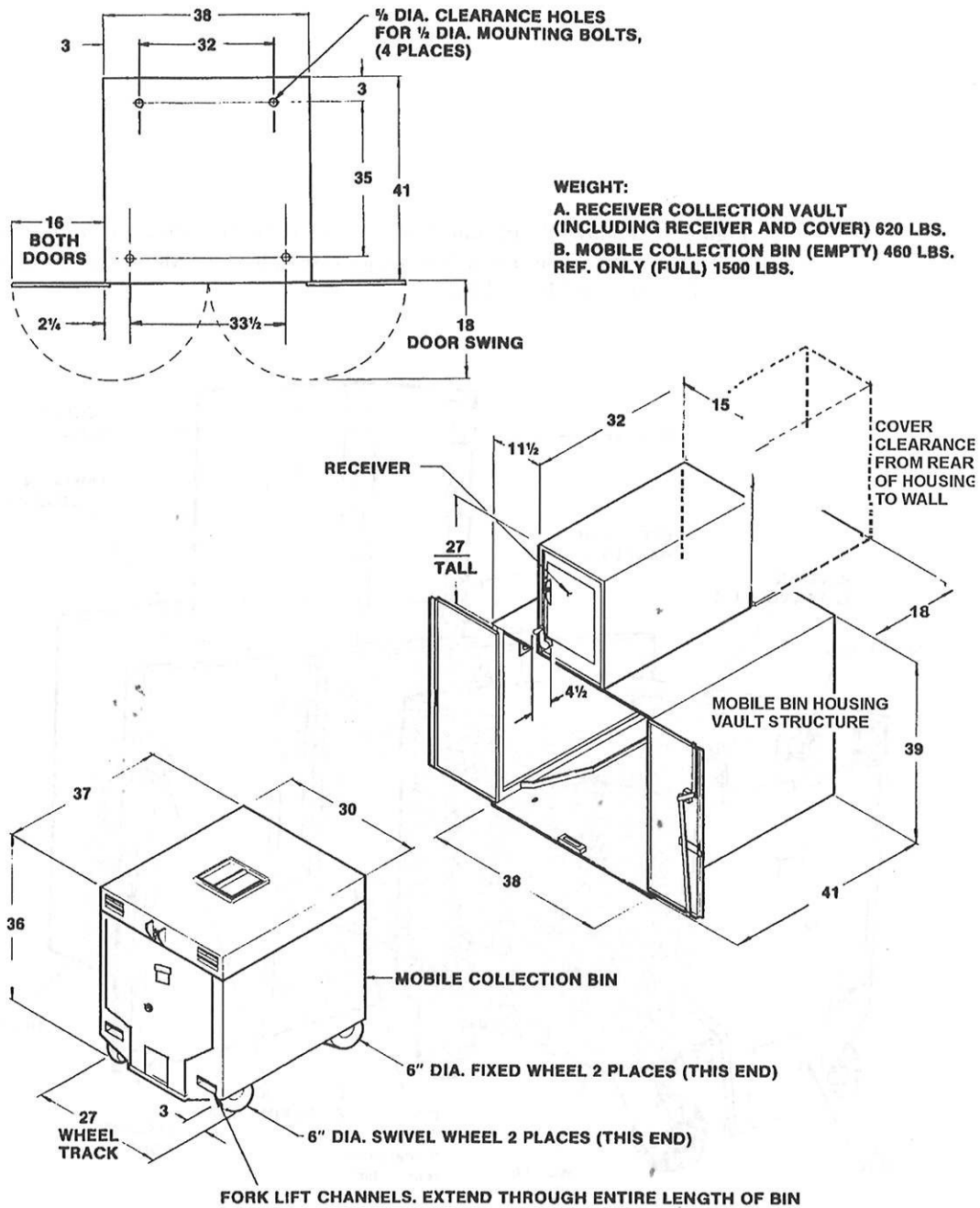

Figure A2-2. Dimensions for Receiver, Housing, & Bin